

OWNER'S MANUAL

OrbiTrekTM

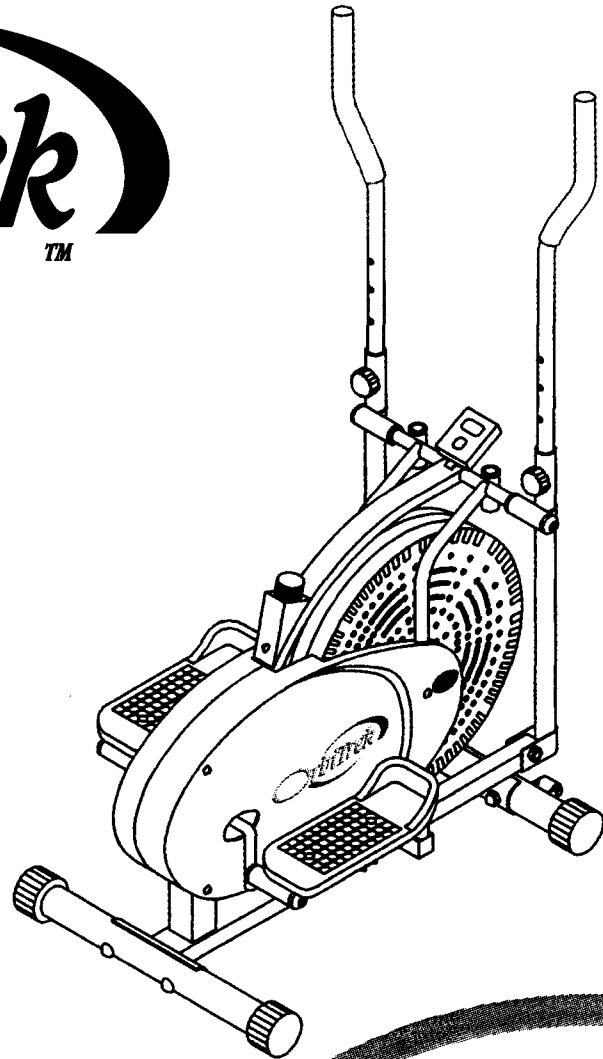

Safety notice	2
Assembly & usage	3-7
Exploded view	8
Parts list	9
Guide au Français	10
Manual en Español	19

Model No. OR1000-PRO

IMPORTANT!

Please read all instructions carefully before using this product. Retain this manual for future reference.

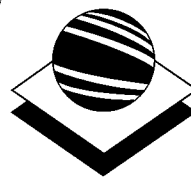

THANE INTERNATIONAL, INC.

IMPORTANT SAFETY NOTICE

Note the following precautions before assembling or operating the OrbiTrek.

1. THE MAXIMUM WEIGHT CAPACITY OF THE ORBITREK IS 250 LBS. Persons whose body weight exceeds this limit should NOT use this machine.
2. Keep children and pets away from the OrbiTrek at all times. DO NOT leave unattended children in the same room with the machine.
3. If the user experiences dizziness, nausea, chest pain, or any other abnormal symptoms, STOP the workout at once. CONSULT A PHYSICIAN IMMEDIATELY.
4. Position the OrbiTrek on a clear, level surface. DO NOT use near water or outdoors.
5. Always wear appropriate workout clothing when exercising. Running or aerobic shoes are also required.
6. Use the OrbiTrek only for its intended use as described in this manual. DO NOT use any other accessories not recommended by the manufacturer.
7. DO NOT place any sharp objects around the OrbiTrek.
8. Handicapped or disabled persons should not use the OrbiTrek without the presence of a qualified health professional or physician.
9. Before exercising, always do stretching first.
10. NEVER operate the OrbiTrek if it is not functioning properly.

WARNING: BEFORE BEGINNING THIS OR ANY EXERCISE PROGRAM, CONSULT YOUR PHYSICIAN FIRST. THIS IS ESPECIALLY IMPORTANT FOR INDIVIDUALS OVER THE AGE OF 35 OR PERSONS WITH PRE-EXISTING HEALTH PROBLEMS. READ ALL INSTRUCTIONS BEFORE USING. THANE INTERNATIONAL ASSUMES NO RESPONSIBILITY FOR PERSONAL INJURY OR PROPERTY DAMAGE SUSTAINED BY OR THROUGH THE USE OF THIS PRODUCT.

SAVE THESE INSTRUCTIONS

ASSEMBLY & USAGE

I. Before you begin

1. **Locate a comfortable work site.** Assemble your OrbiTrek in an open space with adequate ventilation and lighting. Because the OrbiTrek is portable to some extent, you need not assemble it exactly where it is to be used. For your convenience, however, you should avoid hauling the machine across excessive distances, through narrow passageways or over staircases once its assembly is complete. If the OrbiTrek is to be assembled in living quarters, protect the floor or carpet with a large mat before removing parts from carton.
2. **Find your tools.** You will need the following tools to assemble the OrbiTrek.
 - Ruler with both metric and English measurements
 - Adjustable wrench
 - Standard screwdriver
 - WD40 lubricant or Vaseline (if necessary)
3. **Review all safety guidelines** on page 2 of this manual.

II. Identify your hardware

4. **Organize your bolts and nuts** before assembly. Nuts are identified by the diameter of their cavities. For more information, refer to exploded view diagram and parts list on pages 7-8 of this manual. *Note: The illustration below is roughly 60% of actual size.*

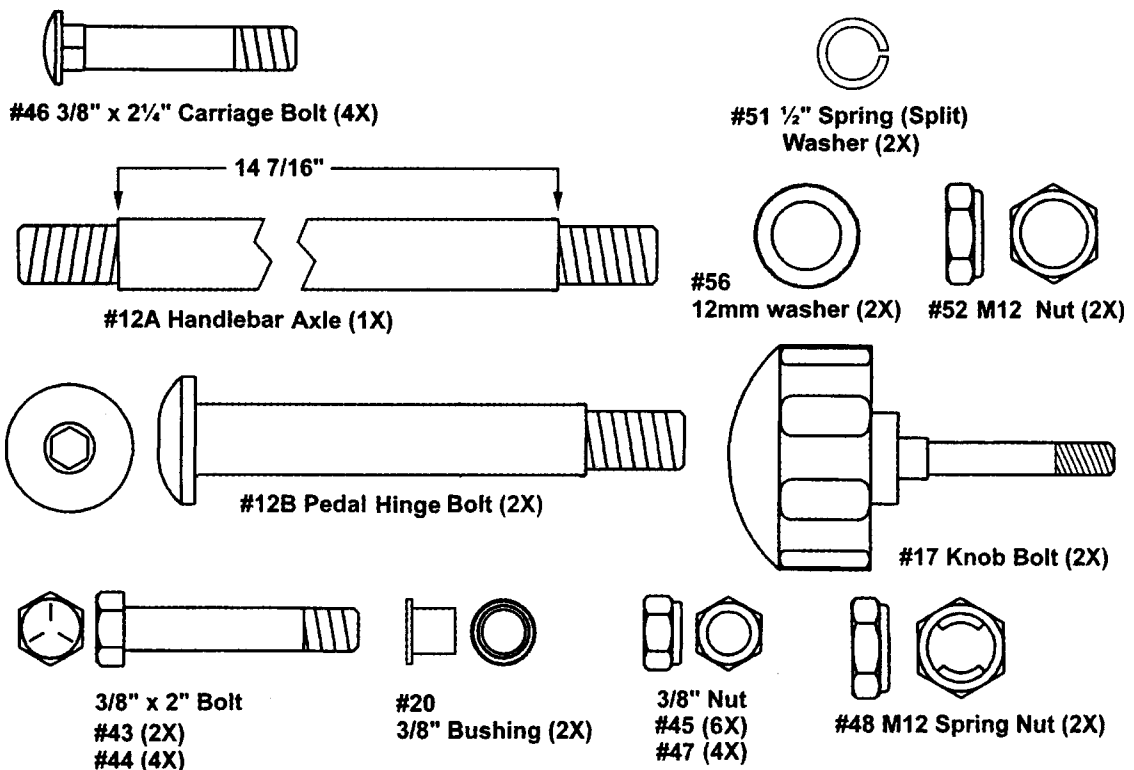

III. Assembling your OrbiTrek

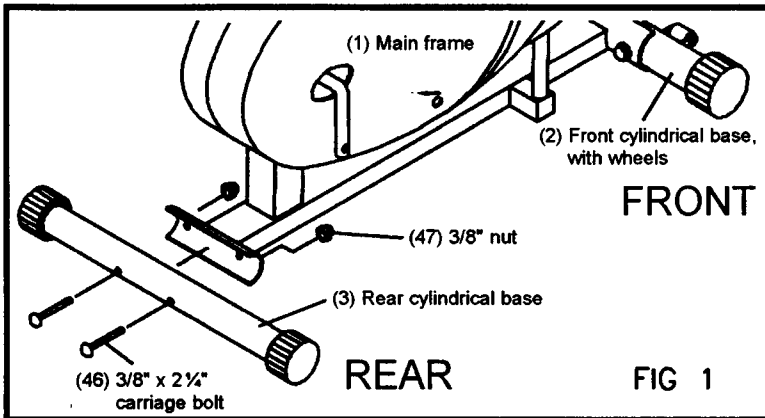

5. Install cylindrical bases (#2 for front, #3 for rear) to the main frame (#1).

Notice that the front base (#2) has wheels for moving your OrbiTrek.

For each base, use two 3/8" x 2 1/4" carriage bolts (#46) and two 3/8" nuts (#47). See Fig. 1.

6. Insert the handlebar axle (#12A) through the main frame. Make sure the axle is centered. If you encounter too much friction, try using WD40 or Vaseline as a lubricant. See Fig. 2.

Steps 7 through 9 describe the assembly for the pedals and coupler bars. Once assembly for one side is complete, repeat these steps for the other side before you proceed to attach the handlebars.

Notice the coupler bar for each side is different (#4 for right side, #5 for left side). A coupler bar is at the correct side of the OrbiTrek when its horizontal pivot tube, which is welded at the top, faces the rear of the machine as seen from the user. See Fig. 2.

7. Attach the coupler bar (#4 at right, #5 at left) to the main frame via the handlebar axle. Again, use WD40 or Vaseline to reduce friction, if needed. Once the coupler bar is correctly situated, fasten the end of the axle with a Ø12mm washer (#56) and a M12 nut (#52). Then cap each end with a rubber cap (#57). See Fig. 2.

8. Insert a pedal hinge bolt (#12B) through the pedal tubing (#6R for right side, #6L for left side). Attach the hinge bolt to the crankshaft (#27), which is already installed within the main frame. Again, use WD40 or Vaseline to reduce friction when necessary. Secure the hinge bolt at the other end with a 1/2" spring washer (#51) and a M12 spring nut (#48). See Fig. 2.

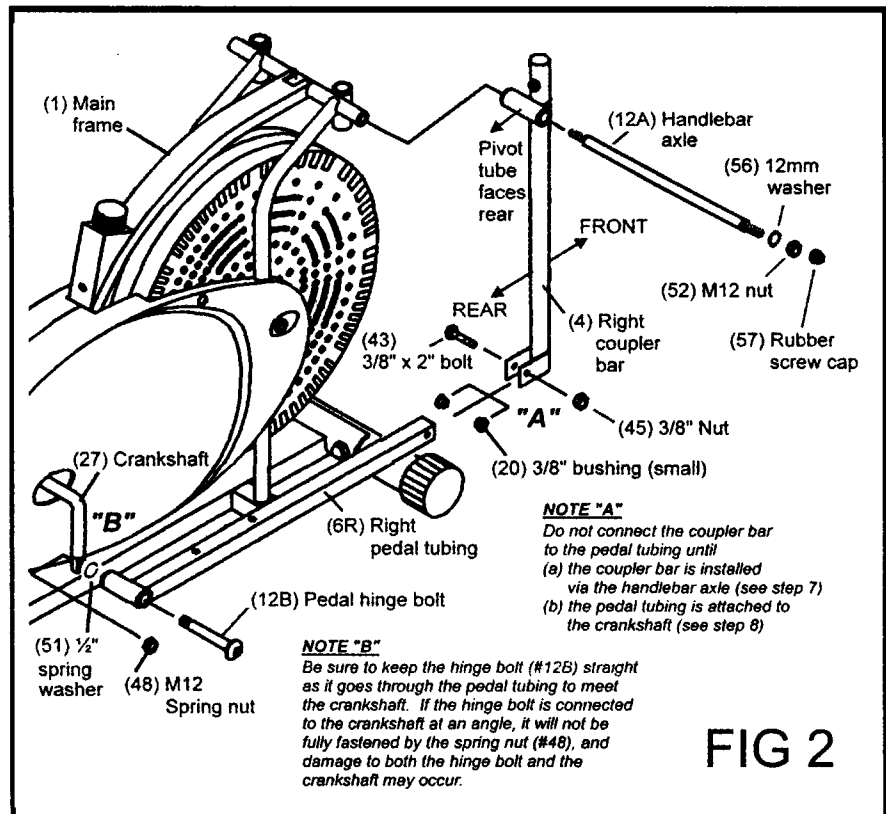
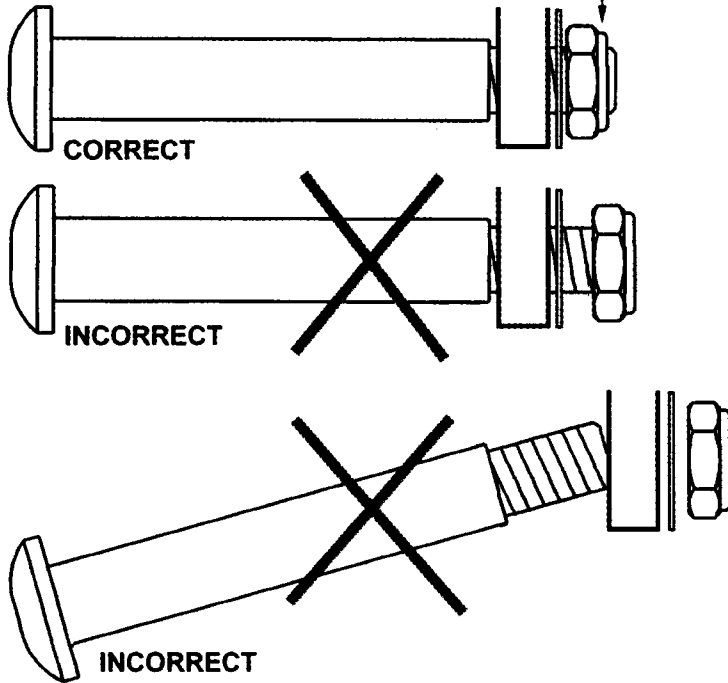

FIG 2

A nylon ring can be seen at the rim inside the spring nut. The hinge bolt must fully penetrate this nylon ring.



IMPORTANT!

The hinge bolt (#12B) must fully penetrate the nylon ring inside the spring nut (#48). This will ensure the stability and durability of your Orbitrek.

In order to install the hinge bolt properly, keep it perfectly straight as the bolt goes through the pedal tubing and the crankshaft. If the hinge bolt is connected to the crankshaft at an angle, damage to both the hinge bolt and the crankshaft may occur.

9. Connect the coupler bar (#4) to the pedal tubing (#6). Note: Do this step ONLY after the coupler bar and the pedal tubing themselves are properly attached to the Orbitrek. Place two $\text{\O}5/8$ " bushings (#20) at either side of the pedal tubing. Then use a $3/8$ " x 2" bolt (#44) and a $3/8$ " nut (#45) to secure the connection. See Fig.2.

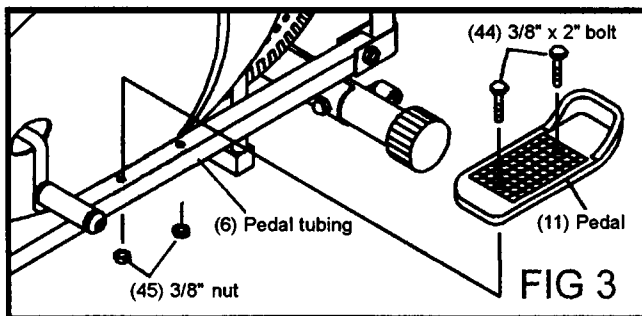

10. Attach a pedal (#11) to a pedal tubing (#6). Use two $3/8$ " x 2" bolts (#44) and two $3/8$ " nuts (#45). See Fig.3.

IV. Handlebars

You can easily switch your handlebars (#7L, #7R) between the dual-action mode and the fixed mode during your workout.

- 11. Dual-action mode:** To allow the handlebars to move along with the pedals, attach them to the coupler bars.

Select a height setting that is comfortable to the user, and make sure both handlebars are set at the same height. Lock each handlebar in place with a knob bolt (#17). See Fig.4.

- 12. Fixed mode:** To keep the handlebars stationary, attach them to the tubing on the main frame between the coupler bars.

As with the dual-action mode, set both handlebars at the same, comfortable height and secure them with knob bolts (#17).

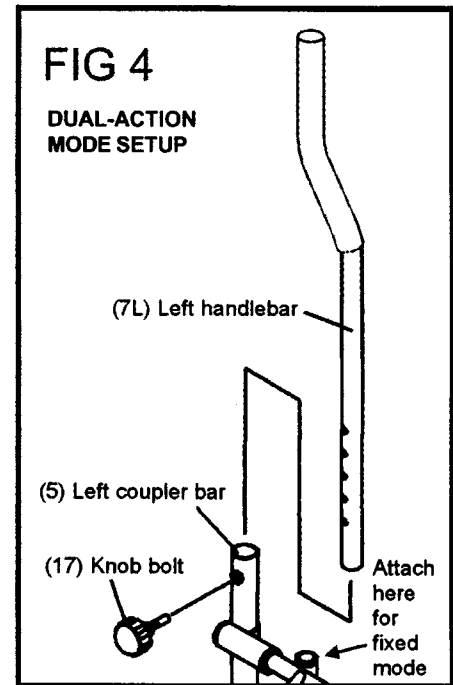

V. Electronic monitor

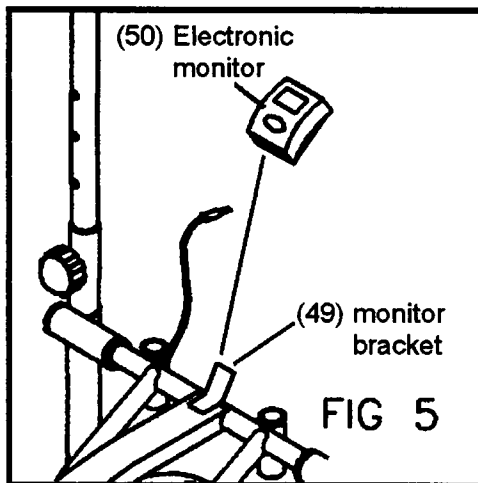

- 13. Attach the electronic monitor (#50) to the main frame via a bracket (#49). Connect the monitor to the sensor wire. See Fig.5.**

With the press of a button, you can set the electronic monitor of your OrbiTrek to display the following information:

- **TIME:** How long you have been exercising
- **SPEED:** How fast you are running
- **DISTANCE:** How far you would have run with your two feet on the ground
- **CALORIE:** How many calories you have burned

The SCAN mode lets your monitor automatically alternate the four readouts in short intervals, so you don't have to stop and press a button to check different information.

The monitor comes with two AA batteries, and turns itself off when not in use to conserve energy. Replace batteries about every four months, depending on frequency of use.

VI. Tension adjustment

The assembly of your OrbiTrek is now complete. As you try it for the first time, you should adjust the tension to a desirable level before you begin a full workout.

14. **For minute tension adjustment**, simply use the tension adjustment knob found at the top center. Tension level can be manipulated this way to vary intensity of workout as you exercise.

15. **For greater tension adjustment**, you may loosen or tighten the friction belt (#35) by re-strapping it. To do so, first turn the tension adjustment knob all the way to the loosest setting. Then re-strap the belt at the buckle on the main frame, just beneath the flat beam at the top center. The more length you allow for the friction belt to wrap around the wheel, the less friction it will cause. Re-adjust the tension knob after you finished re-strapping.

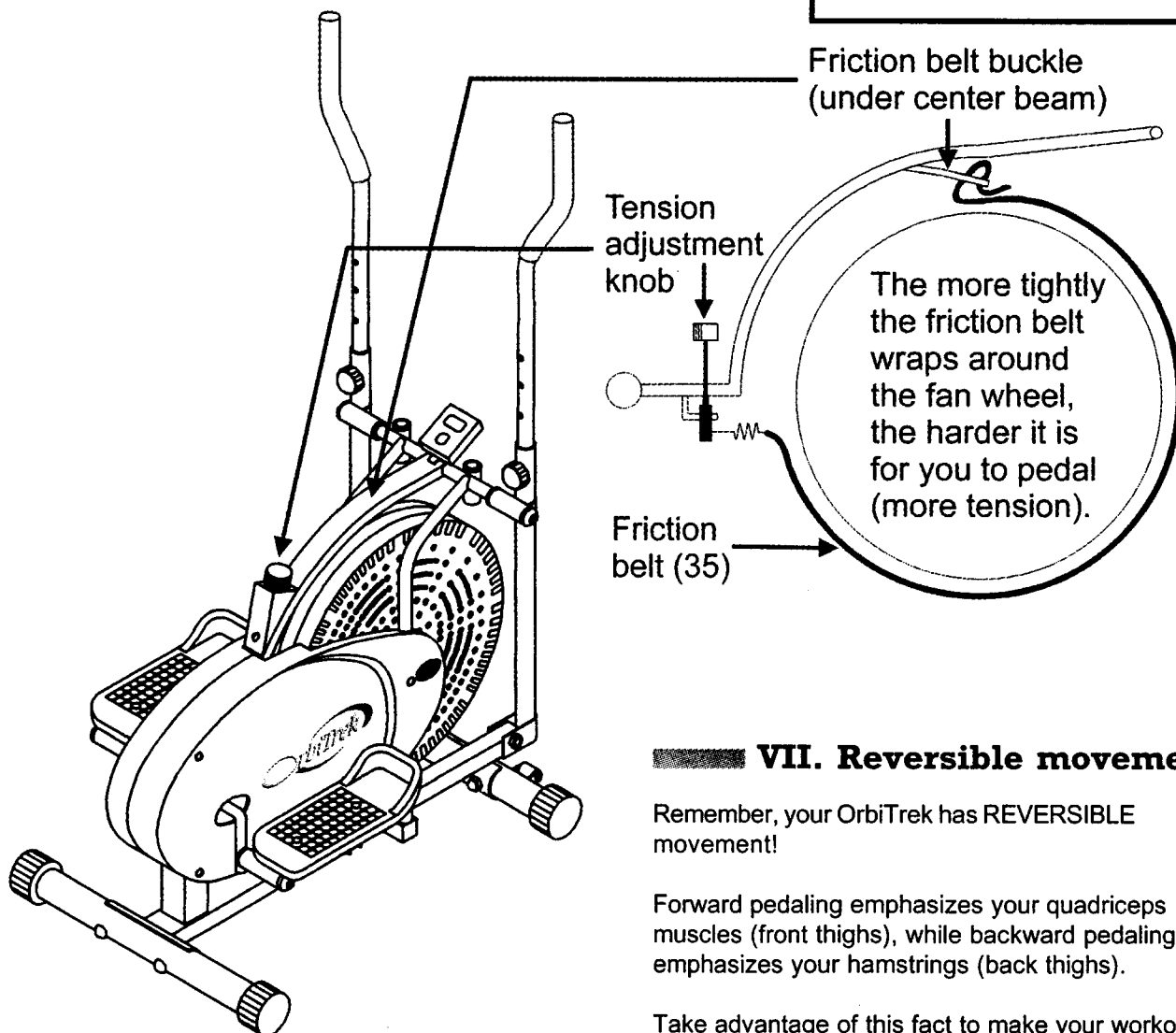
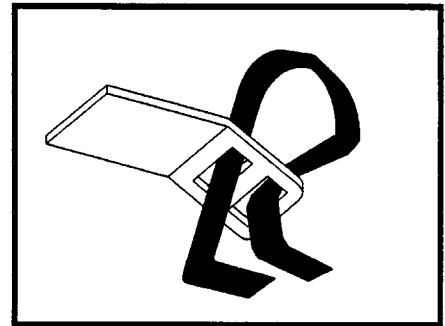

VII. Reversible movement

Remember, your OrbiTrek has REVERSIBLE movement!

Forward pedaling emphasizes your quadriceps muscles (front thighs), while backward pedaling emphasizes your hamstrings (back thighs).

Take advantage of this fact to make your workout less fatiguing, and more fun.

EXPLODED VIEW & PARTS LIST

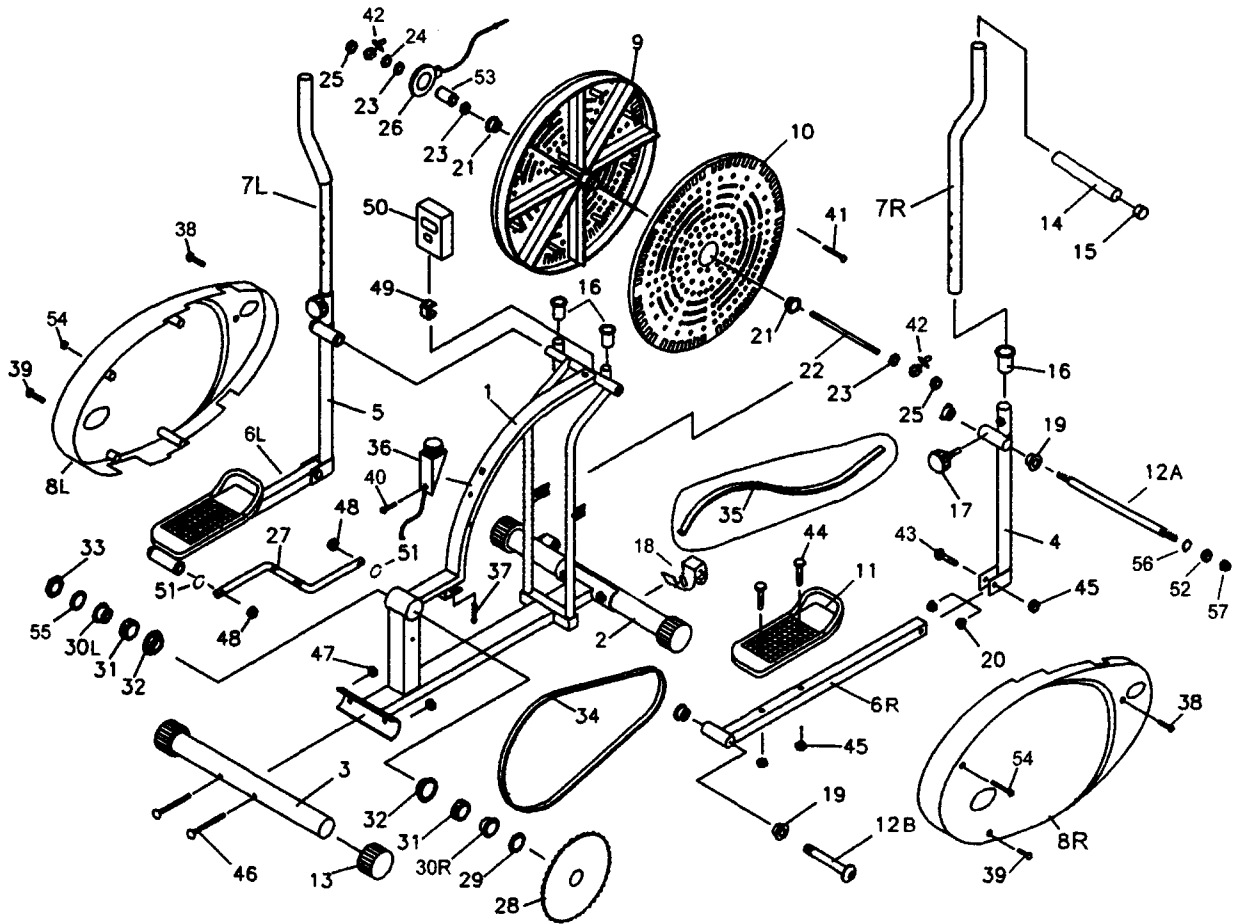

A complete list of parts shown here can be found on the next page.

Most parts here are pre-assembled. This diagram is not intended as an instruction for assembling the OrbiTrek, but simply as a reference in case certain parts need service or replacement.

Thane International, Inc. reserves the right to alter the details of the OrbiTrek as depicted in this owner's manual without prior notice.

Part No.	Description	Quantity	Part No.	Description	Quantity
Pro-1	Main frame	1	Pro-29	Washer for crankshaft	2
Pro-2	Front cylindrical base	1	Pro-30R	Right Ball collar	1
Pro-3	Rear cylindrical base	1	Pro-30L	Left Ball collar	1
Pro-4	Right coupler bar	1	Pro-31	Ball collar bearing	2
Pro-5	Left coupler bar	1	Pro-32	Ball collar brace	2
Pro-6R	Right pedal tubing	1	Pro-33	Nut for crankshaft	1
Pro-6L	Left pedal tubing	1	Pro-34	Chain (204 links)	1
Pro-7R	Right handlebar	1	Pro-35	Friction belt	1
Pro-7L	Left handlebar	1	Pro-36	Tension adjustment knob	1
Pro-8R	Right chain cover	1	Pro-37	Friction belt spring	1
Pro-8L	Left chain cover	1	Pro-38	Bolt for chain covers (M5 x 15mm)	2
Pro-9	Fan wheel hub	1	Pro-39	Bolt for chain covers (M5 x 45mm)	2
Pro-10	Fan wheel cover	1	Pro-40	Screw for tension adjustment knob	1
Pro-11	Pedal	2	Pro-41	Screw for fan wheel (M5)	16
Pro-12A	Handlebar axle	1	Pro-42	Fan wheel adjustment bolt	2
Pro-12B	Pedal hinge bolt	2	Pro-43	Bolt for coupler bars (3/8" x 2")	2
Pro-13	Round cap for cylindrical bases (Ø2")	4	Pro-44	Bolt for pedals (3/8" x 2")	4
Pro-14	Foam grip (Ø1")	2	Pro-45	Nut for pedals and coupler bars (3/8")	6
Pro-15	Round plug for handlebar (Ø1")	2	Pro-46	Carriage bolt for cylindrical bases (3/8" x 2 1/4")	4
Pro-16	Handlebar sleeve (Ø1 1/4")	4	Pro-47	Nut for cylindrical bases (3/8")	4
Pro-17	Knob bolt	2	Pro-48	Spring nut for pedals (M12)	2
Pro-18	Wheel	2	Pro-49	Bracket for electronic monitor	1
Pro-19	Larger bushing for coupler bar (Ø5/8")	8	Pro-50	Electronic monitor	1
Pro-20	Smaller bushing for coupler bar (Ø3/8")	4	Pro-51	Spring (split) washer for pedals (Ø1/2")	2
Pro-21	Bushing for fan wheel axle (Ø10mm)	2	Pro-52	Nut for handlebar axle (M12)	2
Pro-22	Fan wheel axle	1	Pro-53	Bushing for fan wheel axle	1
Pro-23	Nut for fan wheel axle (3/8" x 24mm)	3	Pro-54	Bolt for chain covers	2
Pro-24	Washer for fan wheel axle (Ø10 x Ø30 x 2mm)	1	Pro-55	Bushing for crankshaft	1
Pro-25	Nut for fan wheel axle (3/8")	2	Pro-56	Washer for handlebar axle (Ø12mm)	2
Pro-26	Sensor	1	Pro-57	Rubber screw cap	2
Pro-27	Crankshaft (N bar)	1			
Pro-28	Chain wheel (80T)	1			